

带尾驱动双联叶片泵

T6EE 系列

(T6EES)

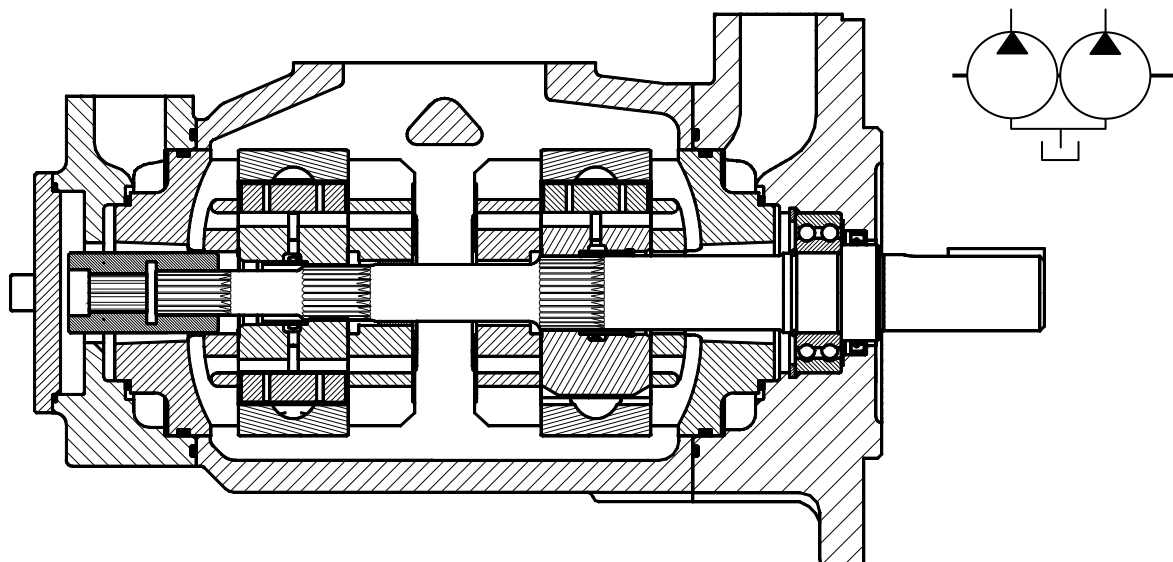

型号说明 ..... 例：T6EE-072-045-2R00-A10-M0

1. **T6EE-072-050-1R00-A10-M0** ..... 系列号

公制安装 (250B4W - ISO-3019)	T6EE
SAE 安装 (SAE-E, 4 螺栓)	T6EES

2. **T6EE-072-050-1R00-A10-M0** ..... 泵芯规格

尺寸 E	
042	132.3
045	142.4
050	158.5
052	164.8
057	179.8
062	196.7
066	213.3
072	227.1
085	269.0

3. **T6EE-072-050-1R00-A10-M0** ..... 轴伸型式

顺时针	R
逆时针	L

4. **T6EE-072-050-1R00-A10-M0** ..... 转向

5. **T6EE-072-050-1R00-A10-M0** ..... 油口布置

6. **T6EE-072-050-1R00-A10-M0** ..... 设计号

7. **T6EE-072-050-1R00-A10-M0** ..... 密封等级

丁晴橡胶：矿物油	1
氟橡胶：矿物油和防火油液	5

8. **T6EE-072-050-1R00-A10-M0** ..... 尾驱动联轴器

未安装尾驱动联轴器	0
SAE-B (13 牙) 扭矩：343 N.m	2
SAE-BB (15 牙) 扭矩：545 N.m	3

9. **T6EE-072-050-1R00-A10-M0** ..... 连接型式

连接型式	公制螺纹	UNC 螺纹
T6EE	M0	-
T6EES	M0	00

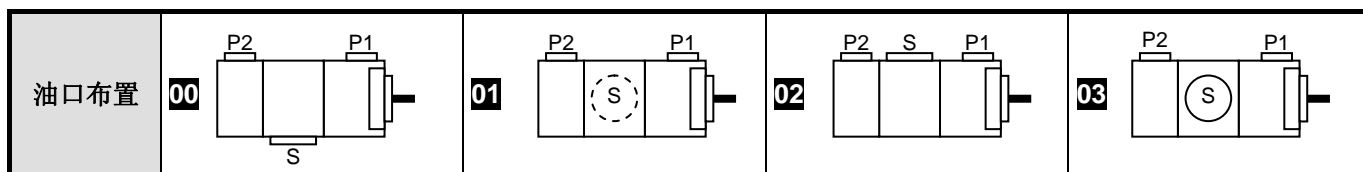

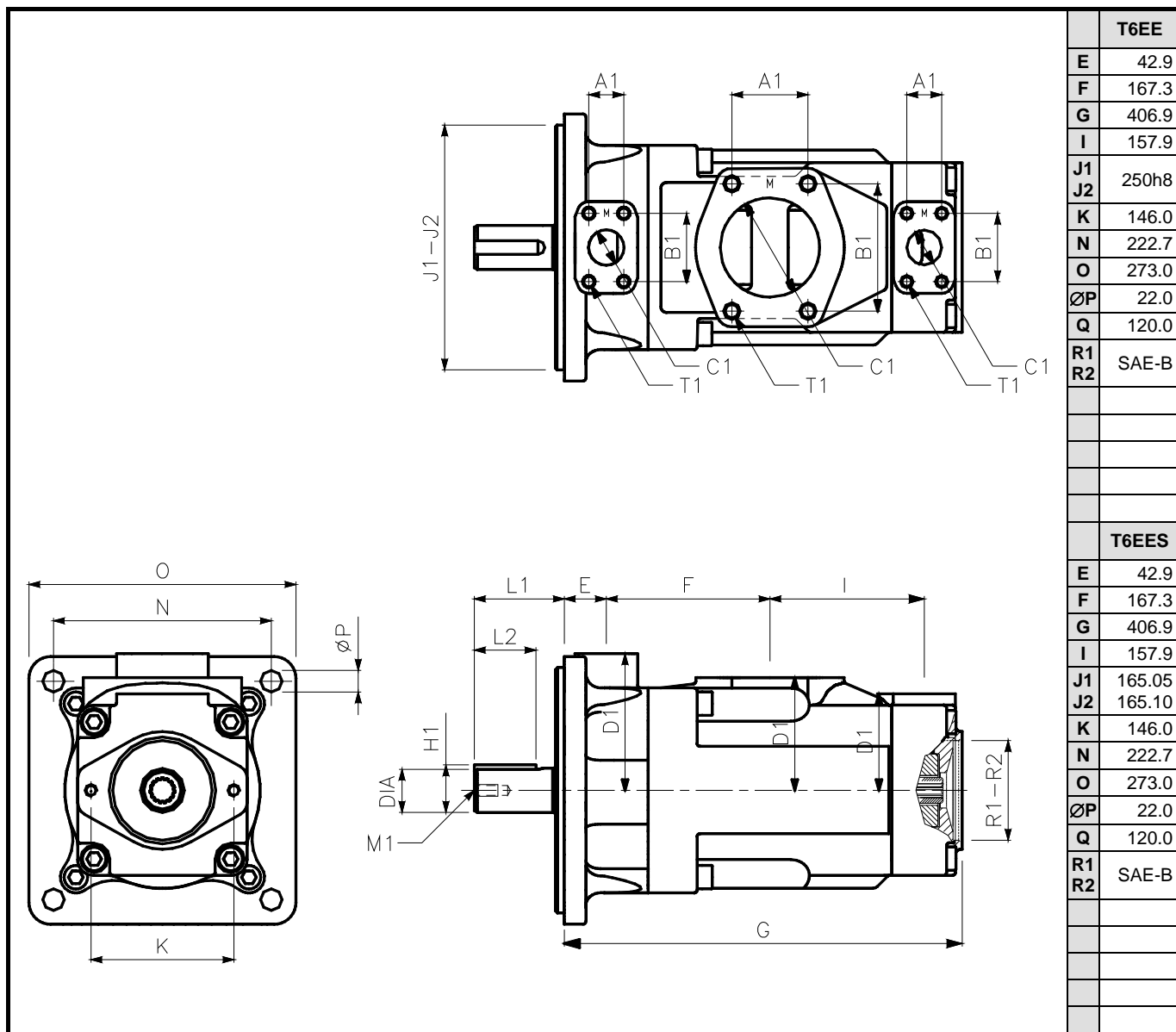

T6EE	
E	42.9
F	167.3
G	406.9
I	157.9
J1	250h8
J2	250h8
K	146.0
N	222.7
O	273.0
ØP	22.0
Q	120.0
R1	SAE-B
R2	SAE-B

T6EES	
E	42.9
F	167.3
G	406.9
I	157.9
J1	165.05
J2	165.10
K	146.0
N	222.7
O	273.0
ØP	22.0
Q	120.0
R1	SAE-B
R2	SAE-B

轴伸		最大扭矩 (N.m)		尺寸 (mm)					
		T6EE	T6EES	L1	L2	直径	K1 x K2	H1	M1
2	平键 : ISO3019-2 (Ø45)	1853		92.0	63.0	45h7	14h8	48.5	M12 x 24.0
1	平键 : SAE CC (Ø38)		1205	90.9	50.8	38.100 - 38.050	9.52 x 9.47	42.36	M10 x 20.0
5	平键 : SAE D&E		1853	100.0	63.5	44.450 - 44.400	11.11x11.06	49.3	½"UNCx24.0
3	花键: SAE CC		2113	62.2	31.5	Class 1-J498b, 12/24 d.p. - 17 牙			
4	花键: SAE D&E		2113	75.0	48.8	Class 1-J498b, 8/16 d.p. - 13 牙			

油口		尺寸 (mm)				T1 口螺纹	
		A1	B1	ØC1	D1	公制 (T6EE)	UNC (T6EES)
P1	SAE 61 - 1½"	35.7	69.8	37.1	139.7	M12 x 30.0	½" 13UNC x 30.0
P2	SAE 61 - 1½"	35.7	69.8	37.1	98.4	M12 x 23.4	½" 13UNC x 23.4
S	SAE 61 - 4"	77.8	130.2	101.6	115.0	M16 x 30.0	5/8" 11UNC x 30.0