

带尾驱动单联叶片泵  
T6CR, T6DR, T6ER 系列

(T6CR)

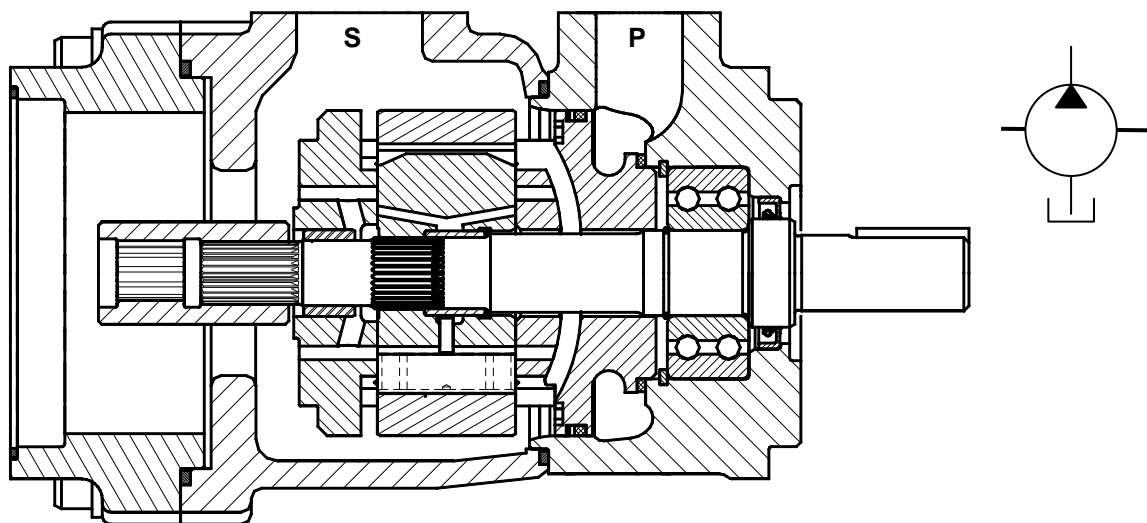

型号说明 ..... 例：T6DR-031-1R00-B10-A1

1. **T6DR-031-1R00-B10-A1** ..... 系列号

系列	T6CR	T6DR	T6ER
----	------	------	------

2. **T6DR-031-1R00-B10-A1** ..... 泵芯规格

T6CR	T6DR	T6ER
003.....10.8	014.....47.6	042.....132.3
005.....17.2	017.....58.2	045.....142.4
006.....21.3	020.....66.0	050.....158.5
008.....26.4	024.....79.5	052.....164.8
010.....34.1	028.....89.7	057.....179.8
012.....37.1	031.....98.3	062.....196.7
014.....46.0	035.....111.0	066.....213.3
017.....58.3	038.....120.3	072.....227.1
020.....63.8	042.....136.0	085.....269.0
022.....70.3	045.....145.7	
025.....79.3	050.....158.0	
028.....88.8		
031.....100.0		

3. **T6DR-031-1R00-B10-A1** ..... 轴伸

4. **T6DR-031-1R00-B10-A1** ..... 转向

顺时针	R
逆时针	L

5. **T6DR-031-1R00-B10-A1** ..... 油口布置

6. **T6DR-031-1R00-B10-A1** ..... 尾驱动安装

	SAE - A	SAE - B	SAE - C
尾驱动连接板	A	B	C

7. **T6DR-031-1R00-B10-A1** ..... 尾驱动联轴器

	SAE	A	B	BB	C	16/32-11 牙
联轴器	1	2	3	4	5	

8. **T6DR-031-1R00-B10-A1** ..... 油口连接

9. **T6DR-031-1R00-B10-A1** ..... 设计号

10. **T6DR-031-1R00-B10-A1** ..... 密封等级

丁晴橡胶：矿物油	1
氟橡胶：矿物油和防火油液	5

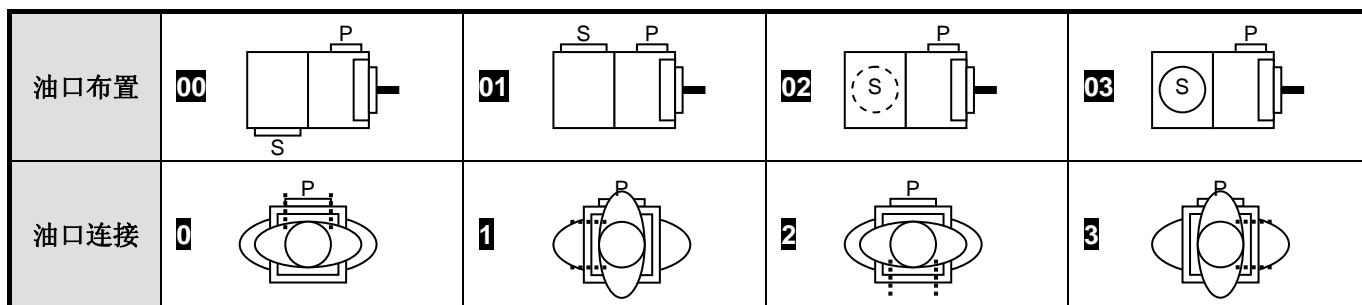

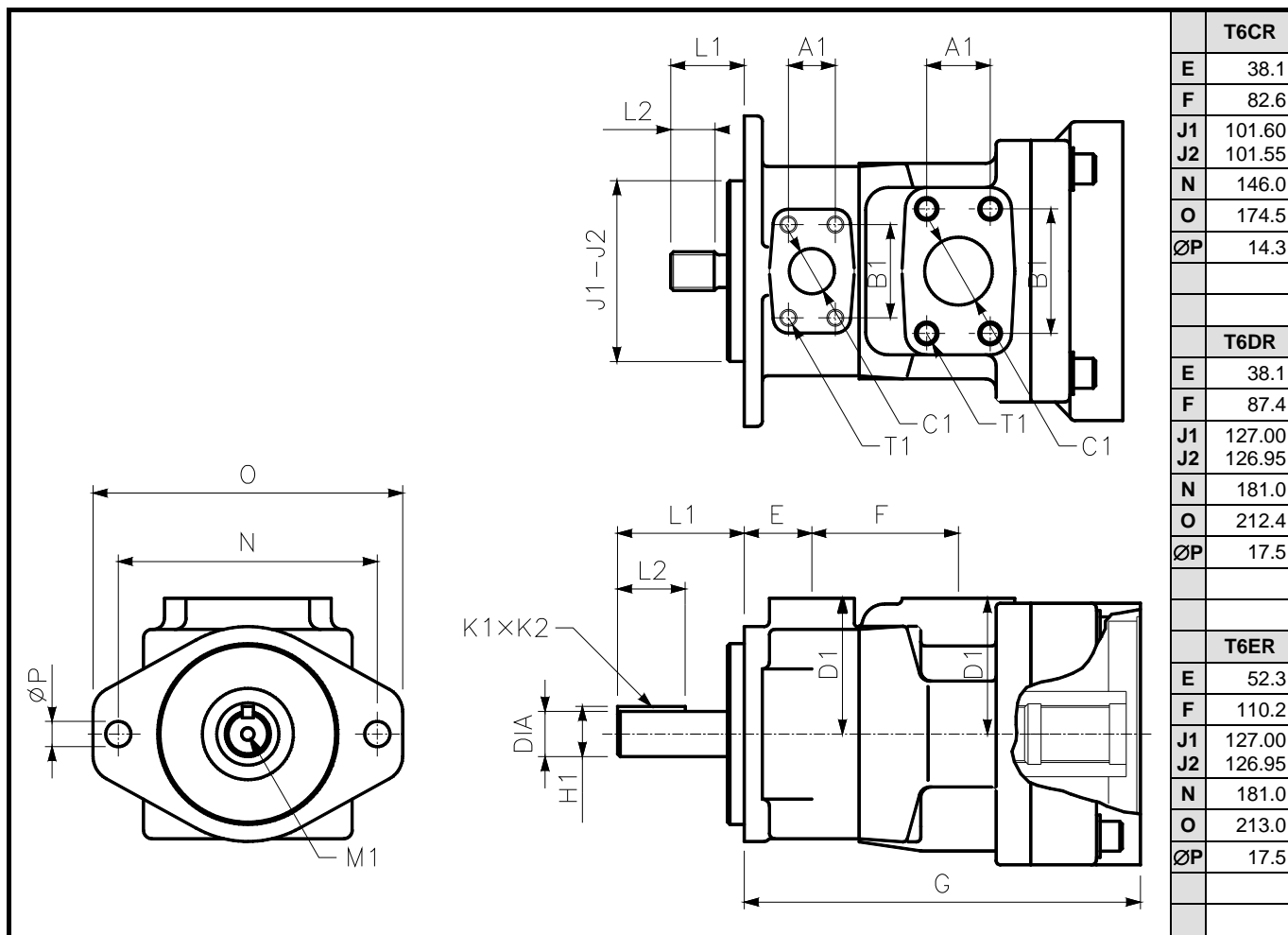

	<b>T6CR</b>
E	38.1
F	82.6
J1	101.60
J2	101.55
N	146.0
O	174.5
ØP	14.3
	<b>T6DR</b>
E	38.1
F	87.4
J1	127.00
J2	126.95
N	181.0
O	212.4
ØP	17.5
	<b>T6ER</b>
E	52.3
F	110.2
J1	127.00
J2	126.95
N	181.0
O	213.0
ØP	17.5

轴伸	最大扭矩 (N.m)			尺寸 (mm)					
	T6CR	T6DR	T6ER	L1	L2	直径	K1 x K2	H1	M1
1	平键: SAE BB (Ø25)	357		71.4	38.1	25.400 - 25.370	6.35 x 6.30	28.22	M8 x 16.0
	平键: SAE C (Ø31)		721	84.1	49.3	31.750 - 31.700	7.94 x 7.89	35.27	-
	平键: SAE CC (Ø38)			90.9	50.8	38.100 - 38.050	9.52 x 9.47	42.36	M10 x 20.0
2	平键: No SAE (Ø22)	238		58.7	31.7	22.225 - 22.200	4.76 x 4.71	24.53	-
	平键: SAE CC (Ø38)		1101	90.4	50.8	38.100 - 38.050	9.52 x 9.47	42.36	M10 x 20.0
3	花键: SAE B	343		41.4	24.5	Class 1-J498b, 16/32 d.p. - 13 牙			
	花键: SAE C		1020	55.2	38.0	Class 1-J498b, 12/24 d.p. - 14 牙			
	花键: SAE C			55.2	27.5	Class 1-J498b, 12/24 d.p. - 14 牙			
4	花键: SAE BB	●		46.2	18.3	Class 1-J498b, 16/32 d.p. - 15 牙			
	花键: SAE CC		2004	61.8	31.5	Class 1-J498b, 12/24 d.p. - 17 牙			
5	平键: No SAE (Ø31)	238		55.5	38.1	31.750 - 31.700	7.94 x 7.89	35.27	M8 x 16.0
	平键: No SAE (Ø35)		927	83.4	48.9	34.900 - 34.850	7.94 x 7.89	38.42	M10 x 20.0

油口	尺寸 (mm)				T1 口螺纹		
	A1	B1	ØC1	D1			
T6CR	P	1"	26.2	52.4	25.4	76.2	3/8"-16UNC x 19.0
	S	1 1/2"	35.7	70.0	38.1	76.2	1/2"-13UNC x 22.4
T6DR	P	1 1/4"	30.2	58.7	31.8		1/16"-14UNC x 22.0
	S	2"	42.9	77.8	50.8		1/2"-13UNC x 23.9
T6ER	P	1 1/2"	35.7	68.9	37.1	98.6	1/2"-13UNC x 23.4
	S	3"	61.9	106.4	75.0	98.6	5/8"-11UNC x 24.0

尾驱动连接板		R1 - R2	D2	G		
代号	类型			T6CR	T6DR	T6ER
A	SAE-A	82.65 - 82.60	M10	209.0	237.0	272.0
B	SAE-B	101.70 - 101.65	M12	223.0	251.0	286.0
C	SAE-C	127.10 - 127.05	M16	233.0	261.0	296.0

请参见附页尾驱动选型表

尾驱动联轴器		最大扭矩 (N.m)		
代号	类型	T6CR	T6DR	T6ER
1	SAE-A	183	183	183
2	SAE-B	343	343	343
4	SAE-C	368	623	1108
3	SAE BB	368	545	545
5	SAE 16/32-11 牙	264	264	264