

## TB 系列 – 单联泵

**8.8 - 39.7 ml/rev. - 190 bar**

型号说明 ..... 例: **TB-011-1R00-A100**

1. **TB-011-1R00-A100**..... 系列号

2. **TB-011-1R00-A100**..... 泵芯尺寸

尺寸 .....	ml/rev	尺寸 .....	ml/rev	尺寸 .....	ml/rev
<b>003</b> .....	8.8	<b>006</b> .....	20.7	<b>011</b> .....	35.6
<b>004</b> .....	12.8	<b>008</b> .....	26.1	<b>012</b> .....	39.7
<b>005</b> .....	16.0	<b>009</b> .....	31.5		

3. **TB-011-1R00-A100**..... 轴伸形式

4. **TB-011-1R00-A100**..... 转向

顺时针 / 逆时针	<b>R / L</b>
-----------	--------------

5. **TB-011-1R00-A100**..... 油口布置

P & S: 正面 / 反面	<b>01 / 00</b>
----------------	----------------

6. **TB-011-1R00-A100**..... 设计号

7. **TB-011-1R00-A100**..... 密封等级

丁晴橡胶: 矿物油	<b>1</b>
-----------	----------

8. **TB-011-1R00-A100**..... 油口连接

P 压力油口		螺纹		SAE, 4 螺栓 法兰
S 吸油口		SAE-12	3/4" NPTF	3/4"
螺纹	SAE-20	<b>00</b>	-	-
	1" 1/4 NPTF	<b>03</b>	<b>0X</b>	-
SAE, 4 螺栓 法兰	1" 1/4	-	-	<b>01</b>

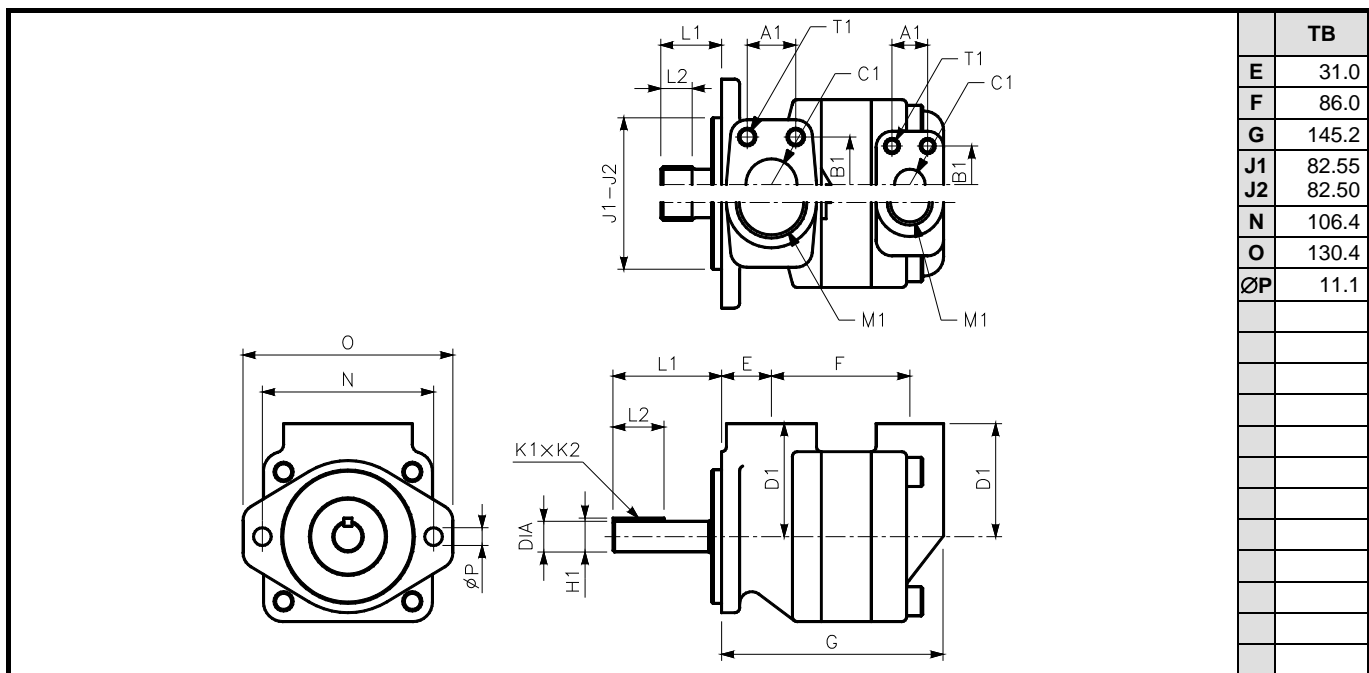

轴伸	最大扭矩 (N.m)	尺寸 (mm)					
		TB	L1	L2	直径	K1 x K2	H1
1 平键: 无 SAE (Ø19)	●		67.50	31.70	19.050 - 19.025	4.775x4.724	21.14
3 花键: 无 SAE	●		38.00	19.05	Class 1-J498b, 16/32 d.p. - 11 牙		
4 花键: SAE A	●		31.30	15.00	Class 1-J498b, 16/32 d.p. - 9 牙		

油口选项			尺寸 (mm)				
			A1	B1	ØC1	D1	T1 口螺纹
00	P	螺纹, SAE	SAE - 12 (1" 1/16 - 12UNF)			69.8	-
	S	螺纹, SAE	SAE - 20 (1" 5/8 - 12UNF)			69.8	-
01	P	SAE - 3/4"	22.2	47.6	19.0	69.8	3/8"-16UNC x 22.0
	S	SAE - 1 1/4"	30.2	58.7	31.8	69.8	7/16"-14UNC x 22.0
03	P	螺纹, SAE	M1 = SAE - 12 (1" 1/16 - 12UNF)			69.8	-
	S	螺纹, NPTF	M1 = NPTF - 1" 1/4			69.8	-
0X	P	螺纹, NPTF	M1 = NPTF - 3/4"			69.8	-
	S	螺纹, NPTF	M1 = NPTF - 1" 1/4			69.8	-